

Tom 56(70), Fascicola 2, 2011

Alternatives for collecting waste water from population centers located in low land areas

Panfil Corina¹ Mirel Ion¹ Gîrbaciu Alina¹

Abstract: This paper outlines the considerations on the use of the alternative sewage wastewater from populated centers, located in lowland areas.

In this article, it is prepared a comparative study of the technical and economical point of view, for three systems of sewerage (gravity sewerage system, gravity sewerage system + pumping, vacuum sewerage system). As a particular case study it was chosen a populated center in the lowland area, with a total of 450 people and 116 parcels.

Keywords: gravity sewerage, gravity sewerage with pumping, vacuum sewerage .

1. INTRODUCTION

Sewer system means all buildings and facilities that collect, transport, purified and evacuate into natural water drainage receiver, respecting the quality requirements imposed by legal regulations in this area. [14]

It is given increasingly more importance to the schemes and technologies for achieving rural sewer systems, both because of their very specific nature, the need for a comfortable fit as well as the great diversity of technical solutions used in the world and in our country for this purpose.

In particular it is noted that new machines have appeared in more effective terms of productivity and technology operational performance, reliable and with high energy efficiencies that can be used with good results in sewer systems populated centers.

All these innovations must be integrated into existing knowledge in the field and made available to designers, clients, practitioners and municipalities with the urbanistic, auction organizers in the field, etc.. to be used to achieve widespread investments in plant exploitation related to sewerage and water treatment plants, to assessing the fairness of the proposed solutions in the application of measures of compliance with operational safety and environmental protection legislation, set of actions that require, obviously, requirements, guidelines and specific regulations. [14]

2. SEWAGE WATER DRAIN

Sewage wastewater from populated centers and industrial units requires for the leaks from the buildings and sanitary facilities the following: pits and

connection canals, main and secondary collectors, pumping and pumping stations, wastewater treatment, sewers and mouths.

The waters retrieved from the sewerage system may be: domestic wastewater, industrial or agricultural buildings, technology and public units.

Proper functioning of the domestic sewerage is influenced by the presence of groundwater and precipitation, which can infiltrate in the sewage systems, causing damage to the treatment process. Also exfiltration of waste water may contribute to the degradation of groundwater, if used as drinking water.

An important role in solving the the sewage of a population center, is to have the knowledge of the origin and characteristics of the wastewater, representing basic data to choosing the materials to piping and sewer systems, to establishing the measures to protect the pipes and other building systems , to establish conditions for industrial the wastewater treatment plants in order to discharge their public sewerage to determine treatment technology and the measures for maintenance and operation of the facilities. [15],[16]

With the exception of water reaching into sewage system, all other types of water have to be standardized as acceptable in the public sewage network system .

The sewerage system can be classified regarding to the system of sewage collection, form of the network and by the way of the flowing water collected..

Following the procedure for the water collection , the sewage systems may be: separative, unitary and mixed.

The separative sewage The separation system, ensure the separate collection of waste water and rain water. The separation system is recommended in the small settlements and large slopes of the land. [5], [14]

The unitary sewage system ensures the collection and transportation both as well as the waste water and the meteoric water. The unit is recommended in the big cities and small slopes of the land.[5], [14]

¹ Politehnica University of Timisoara, Department of Hydrotechnical Engineering, Timisoara, 300022, George Enescu Str., 1/A, E-mail: corina.panfil@yahoo.com

The mixt sewage system is practiced in places where both systems are used, depending on the size of the locality and the land slopes. [5], [14]

Depending on the form of sewage they can be: branched or ring in the case of the vacuum systems.

Upon the way of the flowing waters, sewage systems may be: gravity, gravity with suction (pressure) and of the vacuum.

2.1. Gravity sewage system

The gravity sewage system ensures the free flowing water collection $P = P_{at}$.

This system is the more often found and is recommended in areas with higher slopes of the land. [5]

Gravity sewage systems are composed of: households (1) gravitational coupling (2) connecting homes (3) domestic manholes (4) pipeline network (5), wastewater treatment plant (6), emissary (7) "Fig.1".

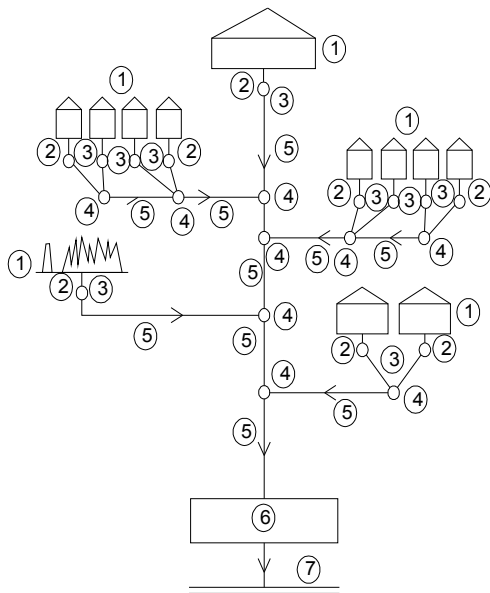

Fig. 1. Scheme of the gravity sewage system operation

The routes and the slopes of channels will be chosen so that the calculated flow in the channel should be achieved the minimum speed per section at least equal to the self-cleaning velocity ($V_{min} \geq 0.7 \text{ m/s}$) and not more than the maximum velocity of nonerosion (v_{max}). The channel slab slope is chosen as much as parallel to the terrain slope it may be, in order to obtain a minimum amount of earthwork at the execution of the sewerage system. The minimum slope of the collector is $I_c = 0.003$ which would ensure the optimal operation of the sewerage system. In "Figure 2", is presented the longitudinal profile of the sewerage system.

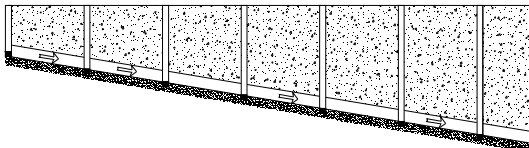

Fig.2. The theoretical longitudinal profile of the gravity sewage system

2.2. Gravity sewage system with pumping

Gravity sewage system with pump is a combined network between the gravity system and the pressure pipe from the pumping station.

In the sewage pumping system ensures the flow of pressurized water collected by pump station $P > P_{at}$.

This system is used if a gravity flow can be made of waste waters. These systems are recommended for areas with sloping land. [5]

Pumping systems with gravity, are similar to those of gravity, shown in Figure 1, to which are added pumping and pumping stations to transport wastewater.

Gravity sewer systems with pumping consist of: households (1) gravitational coupling (2) connecting manholes (3) domestic manholes (4) pipeline network (5), WWTP (6), emissary (7) pumping station (8) "fig.3".

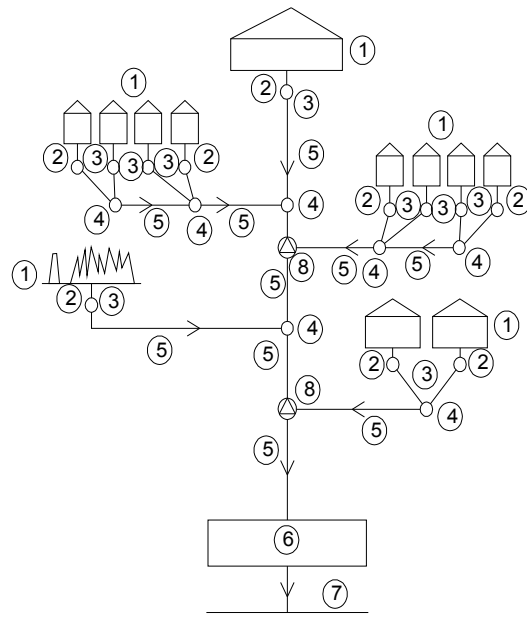

Fig.3. Gravity sewer system with pumping

The paths and slopes channels will be chosen so that the flowing of calculated flow in the channel achieve an average speed per section at least equal to the rate of self-cleaning. Minimum speed of self cleaning has a value of 0.70 m/s . The minimum slope of the collector is $I_r = 0.003$ to ensure an optimum operation of the sewerage system. In "Fig.4" it is presented the longitudinal profile of this drainage system.

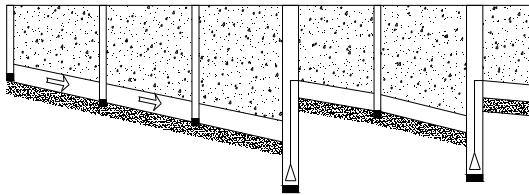

Fig.4. The theoretical longitudinal profile of the gravity sewer system with pumping

2.3. Vacuum sewerage system

The sewage system, vacuum, ensure domestic sewage transport pressures above than the atmospheric pressure $P < P_{at}$. [6], [7], [8]

This system is recommended in the lowland areas and the developed residential neighborhoods near urban population centers.

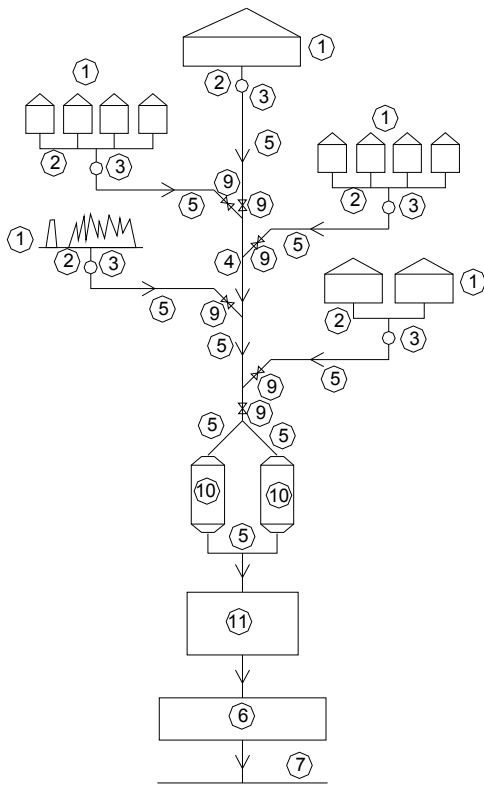

Fig.5. Vacuum sewerage system

Vacuum sewer system layout illustrated in "Figure 5" is in addition to the schemes depicted in "Figure 1", a sectioning valve (9), vacuum tank (10) and vacuum station (11)

Vacuum sewer systems are composed of: households (1) gravitational coupling (2) connecting manholes (3) domestic manholes (4) pipeline network (5), WWTP (6), emissary (7) ; sectioning valve (9) vacuum tank (10) and vacuum station (11) "fig.5".

The usual depth for laying the pipe is from 0.9 to 1.20 m. In the practice the laying of the sewer pipe needs a longitudinal gradient of 2 ‰, and the pipeline route at intervals to create places of "storage" for waste water, called "lifts" are necessary for setting caps. In "Fig.6" has been submitted the longitudinal profile of the sewer system.



Fig.6. Longitudinal profile of the theoretical vacuum sewerage system

The three drainage systems as compared to the operating pressure can act as independent or combined systems..

In choosing the sewage system will be taken into account the following factors: the extent and characteristics of the object focused, and source water characteristics, water quality collected, transported and discharged; features of the land; zone climate, size of the watercourse in the vicinity, which can be used as a receiver, within the permissible discharging dirty substances in the emissary natural phasing investment opportunity, framing in the general management plan.

The system adopted must be based on a calculation based on money, taking into account: the cost of implementation, the slope of the land, consumption of water hydraulic operating conditions, operating. [5]

3. CASE STUDY

As a particular case study was a population center in the lowland area, with a total of 450 people and 116 plots. "Fig.7" maximum hourly flow of waste water, is: $Q_{max} = 8,92 \text{ mc/h}$.

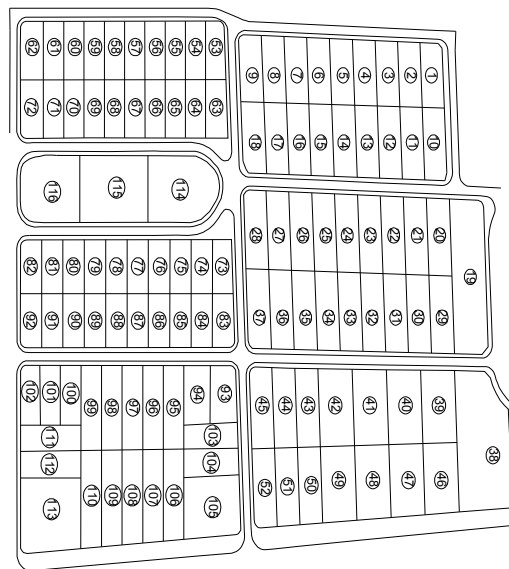

Fig.7. Situation plan

In the this article, it is preparea a comparative study of technical and economical point of view on the three sewer systems.

3.1 Technical Analysis

The network of gravity sewer system will be made of PVC tubes with a diameter of DN 250 and DN 300. The average depth at which the sewage

system will be installed in this case is $h = 1.8$ m, the slope is chosen in this sitem $i = 0,003 \div 0,024$ and to ensure optimum operation of the sewerage system so as to ensure self-cleaning speed channel. "Fig.8".

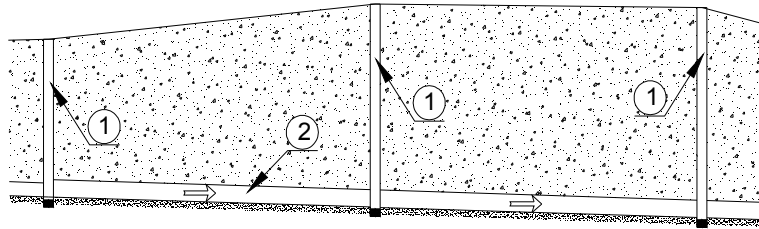

Fig.8. Longitudinal gravity sewerage system
1-household manholes, 2 - gravity pipeline

In the gravitational sewer system with pumping domestic sewage is collected by connection manholes and transported by the gravitational PVC pipe at the pumping station (in this case study are provided two pumping stations). From the domestic sewage pumping station it is pumped to a distance of 50m in the the sewerage network. The discharge pipe will be made of high density polyethylene pipe with a diameter of $\varnothing 110$. "Fig.9".

The average depth at which the sewage system will be installed in this case is $h = 1.5$ m, the slope chosen for this system is $i = 0.003 \div 0.024$ to ensure optimum operation of the sewerage system so as to ensure self-cleaning speed channel. "Fig.9"

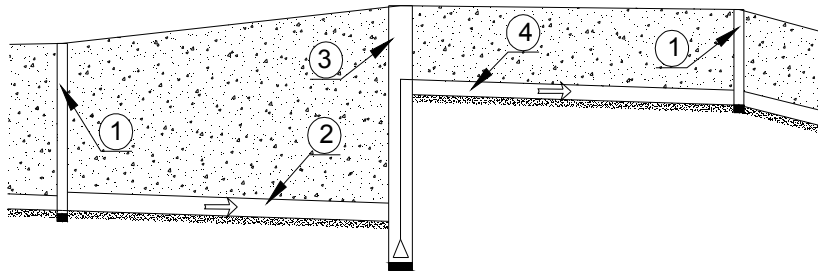

Fig.9. Longitudinal the gravitational sewer system with pumping
1-household manholes, 2 - gravity pipeline, 3-pumping station, 4-pipe discharge

At the gravitational sewage system and pumping system-with the gravitational sewer will be provided manholes and inspection manholes and control of concrete according to the regulations in force, placed in line at distances not exceeding 60 m between them at street intersection, channel diameters changes, changing the channel slope and channel direction changing points. The manholes will be constructed from concrete, diameter 80 cm and $D_{int} = 100$ cm.

Vacuum sewer network system it is under negative pressure generated by a vacuum station.

The network in vacuum sewerage system will be made of high density polyethylene pipes PE-HD PE 100 SDR 13.5 and diameters $\varnothing 110$. $\varnothing 125$. The average depth at which the sewage system will be

installed in this case is $h = 1.2$ m. The slope chosen for this system is $i_c = 0.002$, between two consecutive lifts, lift height h depending on the length of the lift, the maximum number of lifts on a branch $n_{max} = 25$, the minimum number of lifts on a branch $N_{min} = 6$ the maximum distance between two consecutive lifts $L_{max} = 150$ m, the minimum distance between two consecutive lifts $L_{min} = 6$ m, the maximum length of a branching $L_{max} = 25 \times 150 = 3750$ m, a minimum length L_{min} bends = $6 \times 25 = 150$ m maximum allowable basin drains vacuumed $\Delta p_v = -0.6$ to -0.7 bar vacuum valve opening minimum allowable $\Delta p_v = -0.25$ bar maximum number of homes connected to a home collector $N = 4$ to 5 houses "fig.10. [3], [7], [9]

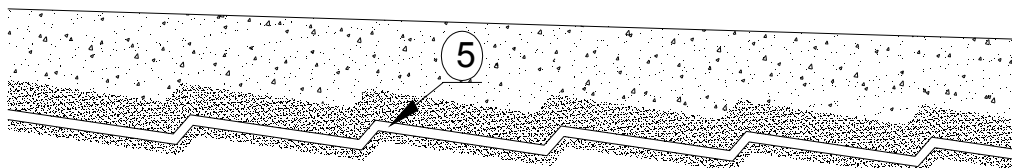

Fig.10. Longitudinal profile vacuum sewerage system
5-vacuum pipe

In every manholes collector, is installed a vacuum valve, which raise the level of waste water, it opens automatically. At this time the atmospheric pressure of 1 bar, normally existing in the home, high-speed push wastewater to sewer, which has an inner absolute pressure 0.3 - 0.5 bar (vacuum 0.6 to 0.7 bar). Valve in the manholes collector aspirates amount of 40 liters of waste water in approx. 3-5 seconds, then into an interval of 3-5 seconds aspirates about 200-300 liters of air needed before the trail pushing stopper. The pressure difference presented in the sewer, transport the mixture bubbles, air and liquid, with a speed of about 20 km / h in a vacuum tank in the station. [1], [2], [3]

The functioning vacuum sewer systems are determined by: the height, the number and the distance between the lifts, type and place of formation of plugs / accumulation of water, time to recovery and rebuilding of vacuum, air-water ratio, the way in which execution is ensured, the maintenance and exploitation facilities. [4], [10], [11]

The lengths of the diameters of the sewerage network, in this case study, are the figures in Table 1. It appears that the length of the pipeline network through the vacuum sewer system is smaller, comparing to the length of the pipeline network to the gravity sewer system or a gravity sewer system with pumping.

Table 1 – Diameter / length of pipe network

No.	Sewage system	Diameter / length of pipe network (m)				
		Dn 250	Dn 300	110	125	TOTAL
1	Gravity sewage system	2.190,0	145,0	-	-	2.335,0
2	Gravity sewage system with pumping	2.080,0	145,0	110,0	-	2.335,0
3	Vacuum sewerage system	-	-	1.920,0	45,0	1.965,0

In the gravitational sewer system and the gravitational sewer system with pumping gravitational connections to the vacuumated manholes connecting buildings will be achieved with a slope $i = 0.003$ to ensure optimum operation of the sewerage system so as to ensure the self-cleaning speed of the channel. The connections will be made of PVC tubes with a diameter of DN 200 "fig.11. The connecting manholes

will be made of concrete or PVC roadway, with diameter $D = 1.0$ m and depth $H = 1.0 \div 1.5$ m. At a manhole may connect only one building. Connections to the vacuumated sewerage system by the gravitational and the gravitational pumping system are composed of: sewerage connection (1) pit connection (2) waste manholes (3). "Fig.11"

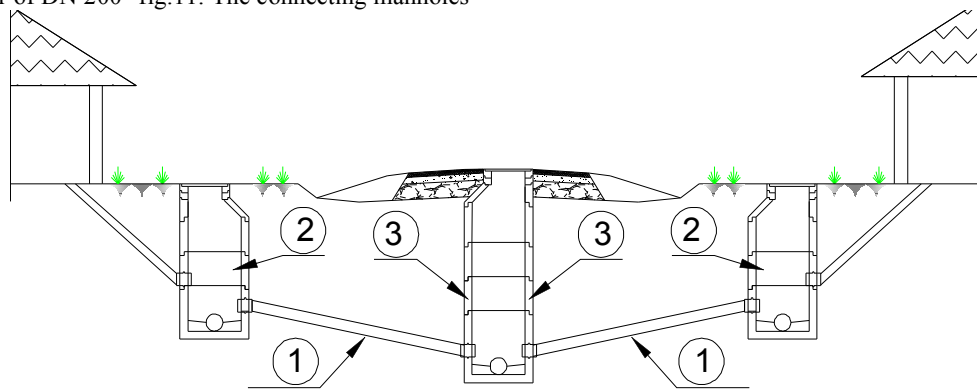

Fig.11. Sewerage connection in the gravitational and the gravitational sewer system with pumping

The vacuum sewer system, connection of buildings to the vacuumated manholes equipped with valve collectors, vacuum is the gravitational slope $i = 0.01 \div 0.04$ in order to avoid spraying the waste water area near the home and the valve arranged inside it. Gravitational couplings are made of PVC DN 90. [4], [5], [7], [12], [9]

Connecting manholes will be made of concrete or PVC roadway, with $D = 1.0$ m and $H = 1.0 \div 1.5$ m, with an intermediate floor. Has a conical bottom (sump) where sewage is accumulated. In the sump, the suction valve descends the vacuum to 5 cm from the bottom. Eccentric placement of the pipeline ensures vortex mixing with waste water. [4]

Branching ducts of buildings are connected to the bottom of the manhole. These routes are gravitational shorter or longer depending on local conditions.

Vacuum valve is fitted on top of the manhole collector and the pipe is fixed by two clamps. The valve is connected to the vacuumated a main collector pipe branch Dn90 mm "Y", outside the manhole. [4] The manhole will be provided with: vacuum valve, air

inlet pipe (Φ 20 mm) to the vacuumated the lower water tank with a capacity of 40 liters. At one manhole may connect 4-5 home homes / households equivalent to 20-25 persons "fig.12.

Sewerage connections to the vacuumated system are composed of: sewerage connection (1) pit connection (2) vacuum valve (4) networking vacuum (5) ventilation system (6). "Fig.12"

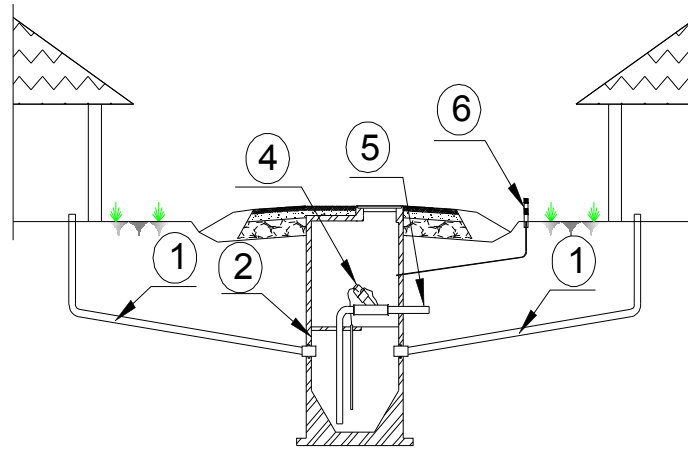

Fig.12. Sewer connection vacuum sewerage system

Waste waters are collected in the lower section of the gravitational coupling manholes. As the wastewater level in the lower section of the basin rises, air is captured in a pipeline sensor, pressure increasing with the level of effluent. This increase in air pressure is converted, through a flexible tube in the

upper section of the vacuum valve, called the controller. While this pressure becomes large enough to operate a switch located inside the controller, which allows transfer of negative pressure in the main valve, causing it to open. "Fig.13" [10]

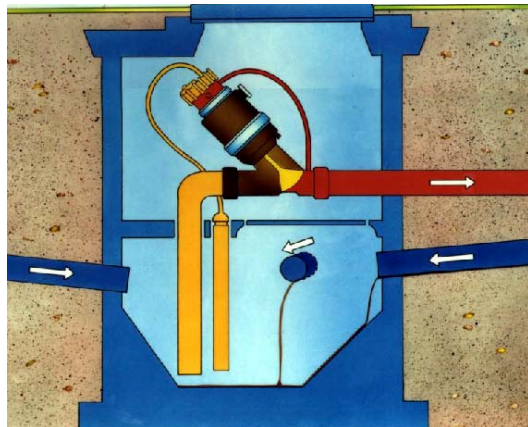

Fig.13. Collector manhole with vacuum valve [10]

Lengths in diameters from sewage connections, in this case study, are the figures in Table 2. It appears that length of pipe connecting the vacuum sewer

system is greater than the length of pipe connecting to the gravity sewer system or a gravity sewer system with pumping.

Table 2 - diameter / length of pipe fitting

No.	Sewage system	Diameter / length of pipe fitting (m)		
		Dn 90	Dn 200	TOTAL
1	Gravity sewage system	-	575,0	576,0
2	Gravity sewage system with pumping	-	575,0	577,0
3	Vacuum sewerage system	1.925,0	-	1.928,0

The assessment of this case study, in Table 3, the total amounts are shown in lei, for each system. It can be seen that the amount of investment in sewerage system-vacuum, is lower than gravity sewer system or a gravity sewer system with pumping.

3.2 Economic analysis

Table 3 - Economic analysis

No.	Sewage system	Economic analysis (lei)			
		Pipe fitting	Pipe network	ml/lei	TOTAL
1	Gravity sewage system	330.513,9	639.041,4	273,7	969.555,3
2	Gravity sewage system with pumping	330.513,9	622.471,5	266,6	952.985,3
3	Vacuum sewerage system	308.987,1	432.090,0	219,9	741.077,1

3.3 Advantages and disadvantages of sewerage systems . [4], [8]

3.3.1 Advantages and disadvantages of gravity sewer system

Advantages:

- easy operation;
- shallow depths of siting the pipeline on level ground with a slope downward;
- can be applied to any type of terrain.

Disadvantages:

- high investment cost;
- high operating cost;
- Large depth of pipeline siting the level ground abd with opposed slope;
- large diameter pipe;
- very large width of the ditch siting pipe;
- route network is rigid;
- frequent clogging of the pipeline caused by a lack of self-cleaning speed and the filling of the pipeline.

3.3.2 Advantages and disadvantages of gravity sewer system and pumped

Advantages:

- easy operation;
- can be applied to any type of terrain.

Disadvantages:

- high investment cost;
- high operating cost;
- pipe-laying great depths;
- large diameter pipe;
- the siting of the pipeline ditch width, very high
- route network is rigid;
- frequent clogging of the pipeline caused by a lack of self-cleaning speed and the filling of the pipeline.

3.3.3 Advantages and disadvantages of vacuum sewerage system

Advantages:

- low investment cost;
- low operating cost;
- long life;

- leakage due to infiltration and seepage are excluded;
- route network is elastic, allowing horizontal and

- vertical avoidance of obstacles without any problems;
- can be applied to the level ground plane;
- small diameter of the pipe;
- the siting of the pipeline ditch width is reduced;
- reduced execution time;
- the system does not allow illegal connections;
- wastewater treatment plant quickly reached.

Disadvantages:

- can not be applied to more local than 10,000 inhabitants.
 - may not apply to areas with opposed slopes.
- [10], [3]

5. CONCLUSIONS

The analysis made in terms of money, it is found that the vacuum sewerage system the recommended method of modern technology, environmental and economic that can be used in populated centers of up to 10,000 inhabitants, situated in the lowlands; tourist complexes, expanding neighborhoods.

It can be seen that the amount of investment for domestic connection to the vacuumated sewerage channel is lower than the investment for connection to gravity or gravity sewer and pumping. This reduced investment value for connecting to the vacuumated vacuum system, is because the connection to the vacuumated a home vacuum valve can be connected 4-5 houses, compared with a gravity system, where connection is made for each house separately.

Also you can see from the economic analysis, the vacuum sewer system including the vacuum station, has a lower value of investment than the gravitational or the gravitational sewer network and pumping. This reduced investment value vacuum system, is due to smaller depth of excavation and reduced diameters compared to other systems (and the siting of the pipeline depths).

“This work was partially supported by the strategic grant POSDRU 107/1.5/S/77265, inside

REFERENCES

- [1] Fabry Gy., Peter A. (2008) The Iseki vacuum sewerage system. Sci. Bulletin of “Polytechnics“ Univ. of Timisoara, Hydrotechnics Series, 53(67) 2, 81-84
- [2] Fabry Gy., Peter A. (2005) The vacuum sewerage system. Conf. for Young Professionals, Bucharest, June 15-17
- [3] Fabry Gy. (2009) Analysis of the parametres of an environmental friendly comunal sewerage system. Ph. D. thesis, Szent Istvan Univ., 2103 Godollo, Hungary, 9-25
- [4] Fabry Gy. (2008a) The desing and establishment of an experimental vacuum fluid conveying pilot plant test rig at the Faculty of Hydrotechnics of the “Polytechnics“ Univ. of Timisoara. Ph. D. thesis, Szent Istvan Univ., 2103 Godollo, Hungary, 9-13
- [5] Giurconiu, M., Mirel, I., Carabet, A., Chivoreanu, D., Florescu. C., Staniloiu, C. (2002) “Constructii si instalatii hidroedilitare” Editura de Vest, Timisoara. 203-260
- [6] Mirel I., Fabry A., Peter A., Carabet A., Stăniloiu C., Olaru I. (2010). Utilizarea sistemelor vacuumate de canalizarea pentru colectarea și evacuarea apelor uzate menajere provenite de pe vatra colectivităților rurale. Rom Aqua an XVI, nr.4/2010, vol.70. 7-14
- [7] Mirel I., Man T.E., Fabry G., Peter A. (2008a) Utilizarea sistemelor vacuumate alternative la canalizarea gravitațională a apelor uzate provenite de la gospodăriile colectivităților situate în zona de șes. Hidrotehnică, 53(9/10), 41-49.
- [8] Mirel I., Man T.E.,(2008) Poligon vacuumat pentru studii și prezentări “Sisteme vacuumate de canalizare menajeră Iseki“ Buletin of Polztechnics Univ. of Timișoara, Hzdrotechnics Series, 53(67)3.
- [9] Mirel I., Retezan A. (1996) Proc. Nat. Conf. of Installations, Sinaia, October.
- [10] Mirel I. (2009) Sisteme vacuumate pentru canalizarea apelor uzate din centrele populate situate în zonele de șes“ Buletin AGIR nr.2-3/2009 aprilie-septembrie. 35-37
- [11] Schribertschnig W., Renner H., Kauch E.P., Schlachter H., Nemecek E. (1995) Abwasser und abfalltechnik. Manz Verlag Schulbuch, Wien.
- [12] *** (2004) An Introduction to Iseki Redivac Vacuum Tehnology. Iseki Vacuum Systems Limited, England, September.
- [13] *** (2009) An Introduction to Iseki Redivac Vacuum Tehnology. Sewage collection system the vacuum way. Redivac Limited. Iseki Vacuum Systems Limited, England, October
- [14] *** (2004) Ghid de proiectare, execuție și exploatare a lucrărilor de alimentare cu apă și canalizare în mediul rural. indicativ GP 106—04
- [15] *** (2006) Legea 265/2006 privind protectia mediului.
- [16] *** (2005) NTPA 002/05 privind conditiile de evacuarea apelor uzate in rețelele publice de canalizare.
- [17] *** (2002) SR EN 1091/2002 Rețele de canalizare sub vid, in exteriorul cladirilor.